



nexia
320 *ix* Z **MRC**
23-69mm AUTOFOCUS ZOOM CAMERA

Owner's Manual



CERTIFIED PHOTOFINISHING SERVICE

- Have your film processed by a Photo Finisher which displays the above sign.
- Different Photo Finishers may provide different services. Consult them for details of their services.



The "CE" mark certifies that this product satisfies the requirements of the EU (European Union) regarding safety, public health, environment and consumer protection. ("CE" is the abbreviation of Conformance Europeenne.) This product conforms with Directive 89/336/EEC.



CONTENTS

FEATURES	2
PART NAMES	3
ATTACHING THE STRAP	4
LOADING THE BATTERY	4
SETTING THE DATE	6
SELECTING THE DATE MODE	7
TURNING THE POWER ON/OFF	9
LOADING THE FILM CARTRIDGE	10
SELECTING THE PRINT FORMAT	12
TAKING PICTURES	14
USING THE AUTO-FOCUS LOCK	17
UNLOADING THE FILM CARTRIDGE	18
FILM CARTRIDGE MID-ROLL CHANGE FUNCTION	20
SELECTING THE EXPOSURE MODE	23
SELECTING SELF-TIMER MODE	27
ERRORS, POSSIBLE CAUSES, AND REMEDIES	28
SPECIFICATIONS	30
CAMERA CARE AND CAUTIONS	31

FEATURES

Thank you for purchasing our product. Read and understand the following manual to insure correct use.

- Auto Focus 23–69mm Zoom
- Simple and error-free Drop-In Loading
- Mid-Roll Change
- 3 Selectable Print Formats
- Print Quality Enhancement Through Information Exchange System
- Auto Flash
- Automatic Film Advance and Rewind
- Auto Focus
- Auto Exposure
- Film Safety Lock
- Date or Time Printing Capability

PART NAMES

(Refer to the illustrations while you read this manual)

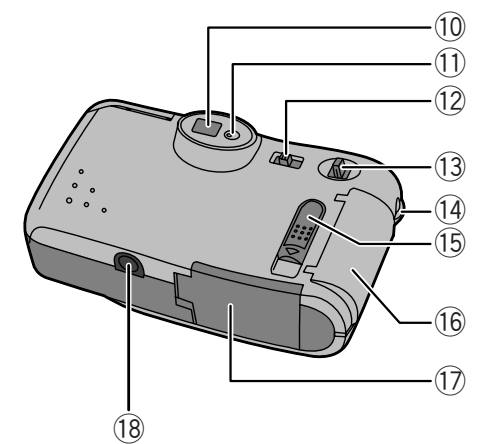
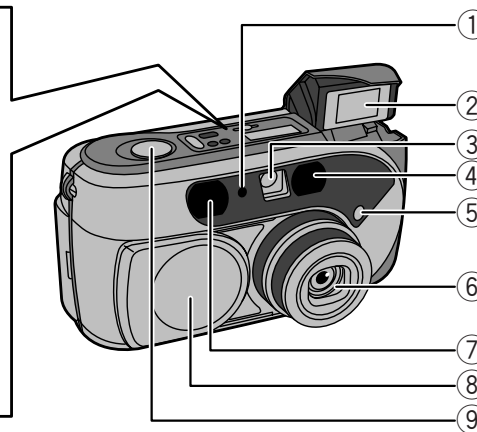
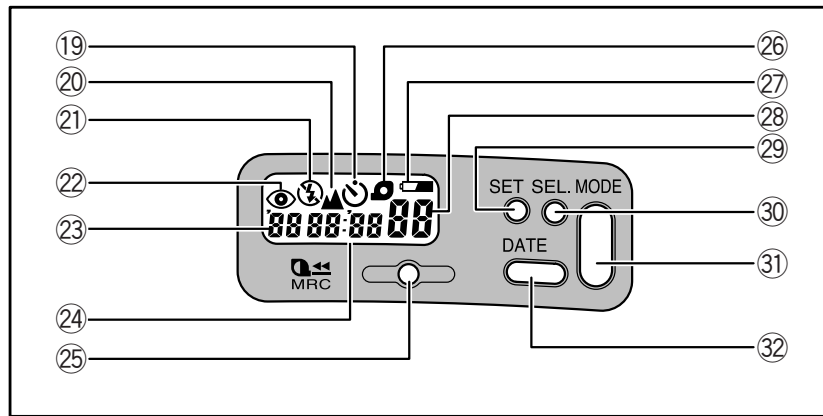

Liquid Crystal Display

- ①⑨ Self-timer Mode Sign
- ②⑩ Landscape Mode Sign
- ③⑪ Back Light Compensation/Flash Off Mode Sign
- ④⑫ Red-eye Reduction Flash Mode Sign
- ⑤⑬ Date Display (Type of Film Cartridge/Camera ISO Display)
- ⑥⑭ Liquid Crystal Display (LCD)
- ⑦⑮ MRC Button (Mid-Roll Change Button)
- ⑧⑯ Film Cartridge Mark
- ⑨⑰ Battery Capacity Sign
- ⑩⑱ Exposure Counter
- ⑪⑲ SET (Date Set) Button
- ⑫⑳ SEL. (Date Select) Button
- ⑬㉑ MODE Button
- ⑭㉒ DATE Button

- ① AE Window
- ② Flash
- ③ Viewfinder Window
- ④ AF (Auto focus) Light Emitter Window
- ⑤ Red-eye Reduction/Self-timer Lamp
- ⑥ Fujinon Lens
- ⑦ AF (Auto focus) Light Sensor Window
- ⑧ Slide Cover
- ⑨ Shutter Release Button
- ⑩ Viewfinder Eye-piece
- ⑪ AF Lamp (green)
- ⑫ Format Selector
- ⑬ Zoom Lever
- ⑭ Strap Lug
- ⑮ Film Cartridge Compartment Cover Release Knob
- ⑯ Battery Compartment Cover
- ⑰ Film Cartridge Compartment Cover
- ⑱ Tripod Socket

ATTACHING THE STRAP

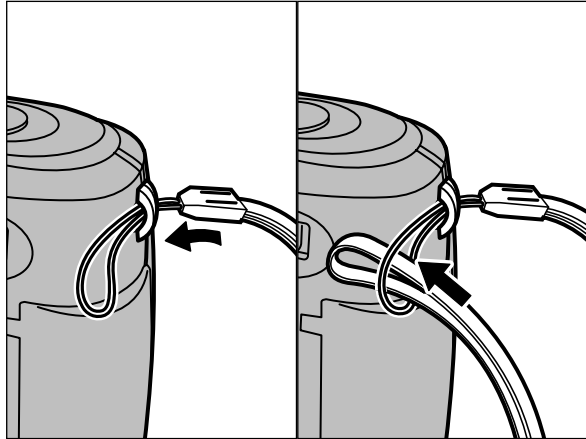

Fig. 1

Attach the strap as illustrated.

- * When using a commercial strap, check the strength and other properties of the strap. Because straps for cellular telephones, PHS, etc. are for light devices, be especially careful when using them.

LOADING THE BATTERY

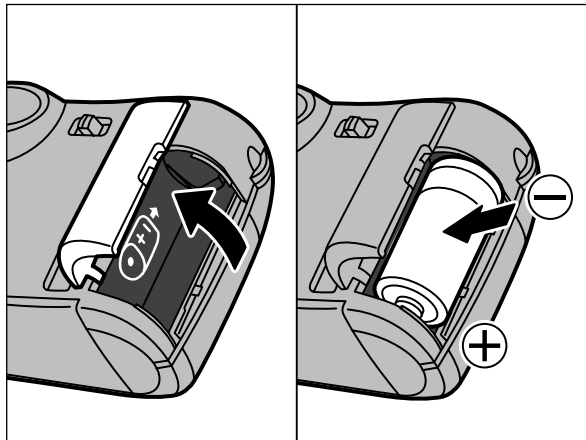

Fig. 2

Lithium battery to be used: CR123A/DL 123A or equivalent (one)

Open the Battery Compartment and insert (one) 3V Lithium battery.

- * Be sure to reset the date when replacing battery.
- * Do not load the cartridge before inserting the battery.
- * One lithium battery has enough power for taking approximately 300 shots (Based on our test conditions). If multiple rolls of film are being used such as for vacation or traveling where batteries may be difficult to obtain, it is advisable to carry a spare.

* When inserting battery, lens may move if camera is in the on position. This is a normal occurrence, not a problem.

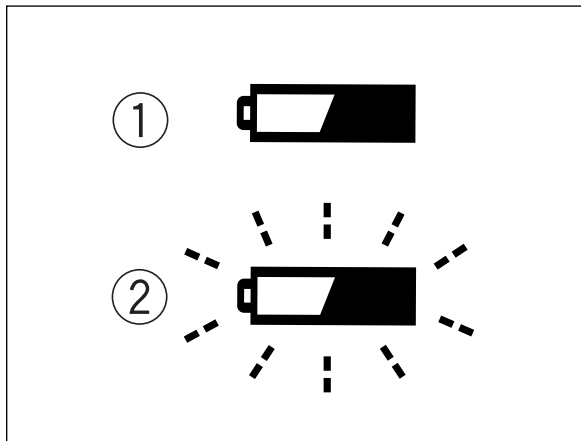
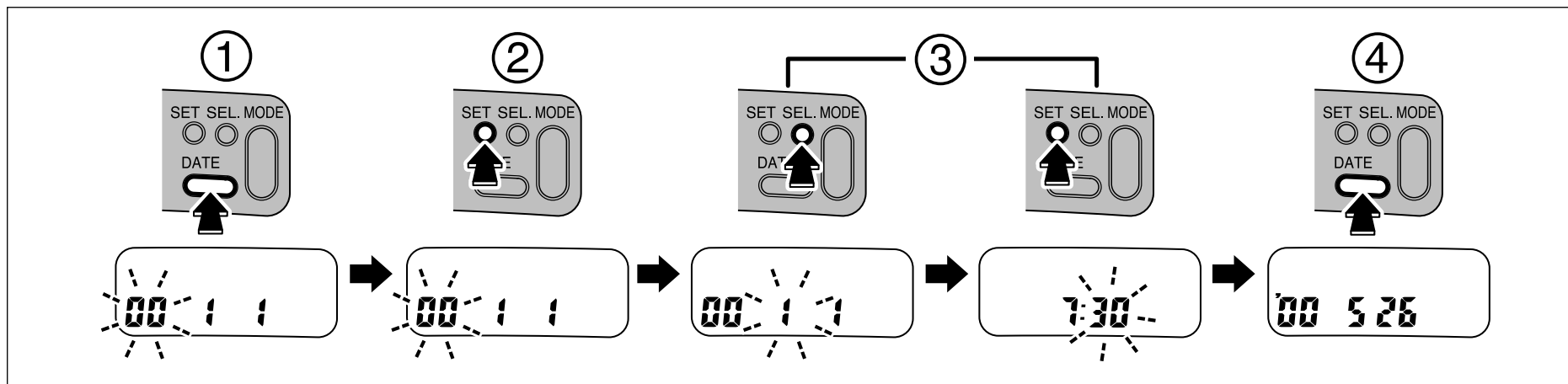

Fig. 3

Once the power is on, you can check the battery capacity display on the LCD.

- ① on : Battery capacity is insufficient; provide a new battery.
- ② blink: Shutter release will not trip because the battery has no charge; change the battery.



SETTING THE DATE (YEAR : MONTH : DAY/HOUR : MINUTE)

Fig. 4

- ① Press the DATE Button for more than 2 seconds, until the year number blinks.
- ② Press the SET Button and adjust the numbers that blink.
- ③ Press the SEL. Button to select the position of the blinking sign year → month → day → hour → minute order, and adjust each figure using the SET Button.

Adjustable items are as follows.

Year	: '99 - '30	(1999 - 2030)
Month	: 1 - 12	Day : 1 - 31
Hour	: 0 - 23	Minute : 00 - 59

- ④ After adjusting the year → month → day → hour → minute, press the DATE Button.
 - * The year, month, and day change together with the hour and minute.
 - * To set the hour or minute by radio, press the DATE Button when the time signal announces zero.

SELECTING THE DATE MODE

Fig. 5

With the Advanced Photo System



The date (year:month:day / hour:minute) can be printed on the front and back of the print. Front printing can be seen when inserted in an album and back printing is convenient for cataloging.

- * Changes, such as eliminating the date, are possible when reprinting (Some photo-finishers may not support this feature).
- * With some backgrounds, the date display on the front may be difficult to see.

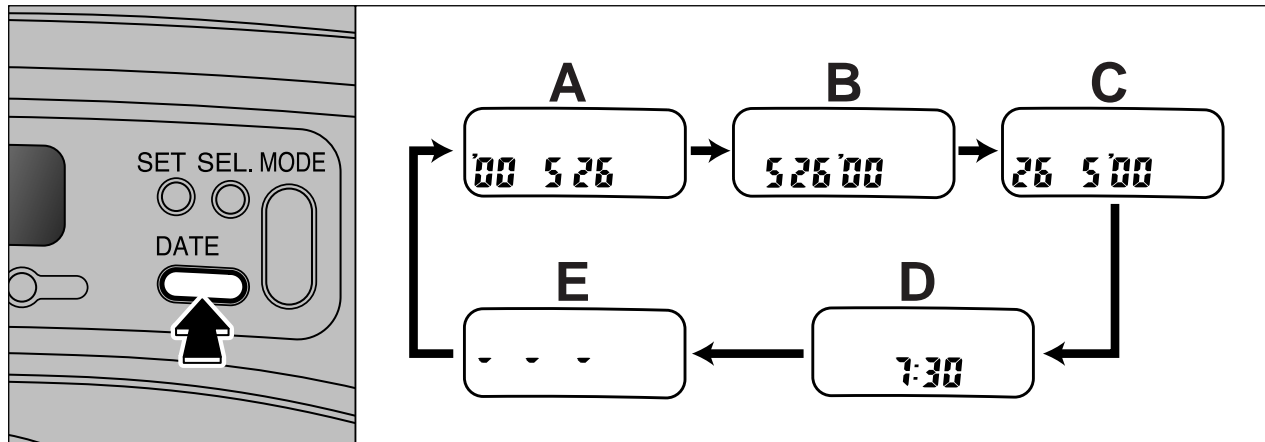

Fig. 6

Each time the DATE Button is pressed, the date format changes in sequence.

- A Year-Month-Day
- B Month-Day-Year
- C Day-Month-Year
- D Hour-Minute
- E No print

The indicated mode is recorded when the picture is taken, and printed on the front and back of the print when printed.

- * Some Print Service shops may not support Front printing.
- * Nothing will be printed on the print when the “- - -” mark is displayed.

TURNING THE POWER ON/OFF

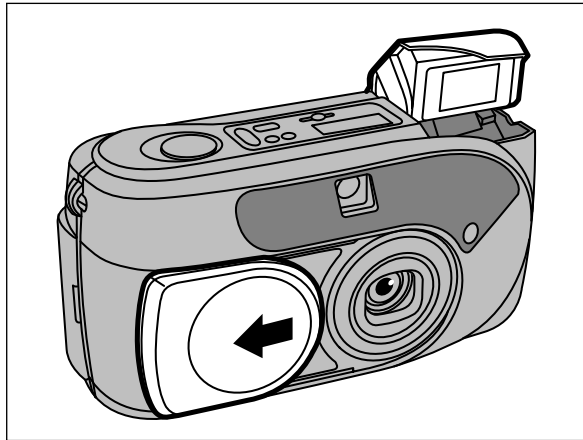

Fig. 7

When the slide cover is opened by sliding it fully in the arrow direction, the power is turned on, the flash lamp pops up, the lens advances, and the camera enters the "Ready-to-Shoot" state. When the slide cover is closed, the power is turned off.

- * When turning on the power, do not press the lens with your finger. The camera may malfunction.
- * If the camera is not operated in the "Shoot" state for 5 minutes, the power is automatically turned off. If the slide cover is closed, then reopened in this state, the camera will be set to the "Ready-to-Shoot" state.
- * When the power is turned off, all functions are canceled except Red-eye reduction modes.

LOADING THE FILM CARTRIDGE

Fig. 8

With the Advanced Photo System

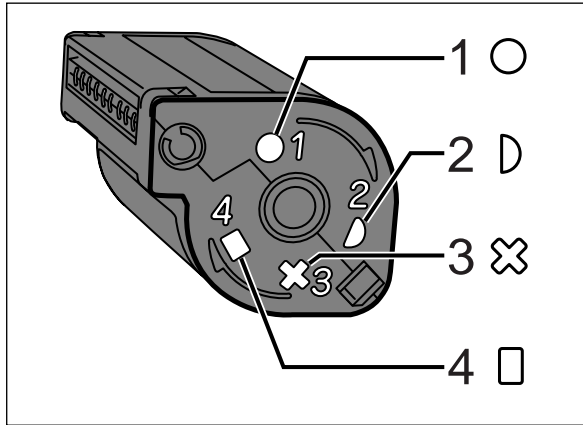

IX240 Cartridge film is used.

* Do not load the cartridge before inserting the battery.

* Confirm that the ○ and D signs on the film cartridge are white. Cartridges in which the ✕ and □ signs are white cannot be used. (Optical Double Exposure Prevention.)

(1 unexposed 2 partial 3 exposed 4 processed)

Fig. 9

After closing the slide cover, (①) move the Film Cartridge Compartment Cover Release Knob in the arrow direction, open the Film Cartridge Compartment Cover.

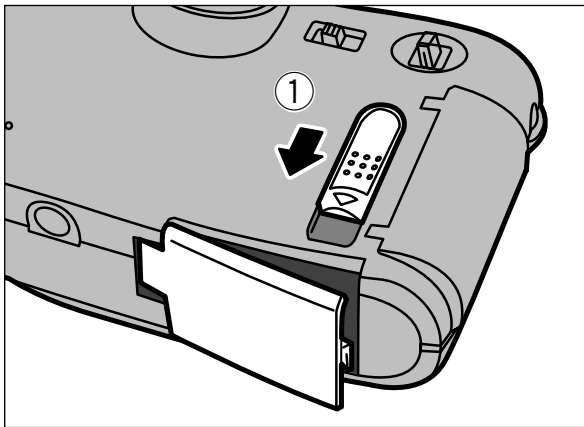

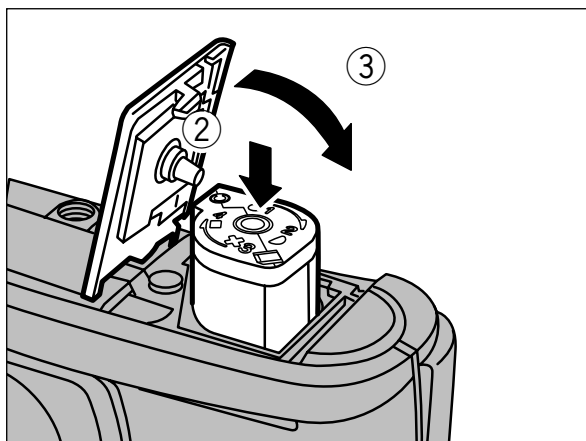

Fig. 10

(2) Turn the camera over and drop in the film cartridge.

(3) Close the Film Cartridge Compartment Cover.

* Do not apply unnecessary force to the Film Cartridge Compartment Cover.

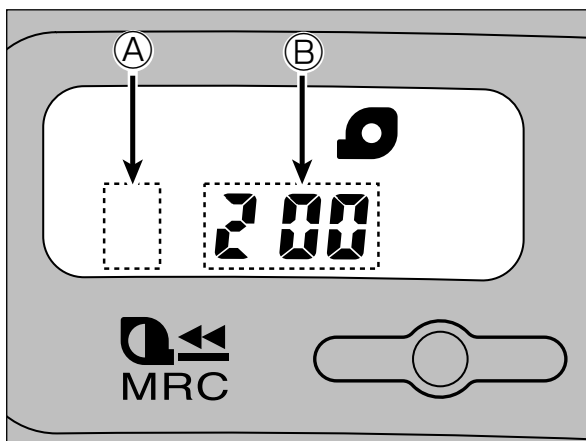



Fig. 11

When the Film Cartridge Compartment Cover is closed, the film is automatically advanced and “” is displayed on the LCD. While the film is being advanced to the first frame, the film type and speed are displayed.

(A): Type of Film Cartridge)

(B): Film speed)

Type of Film Cartridge

Color Negative	Positive	Black and White	Other
No display	<i>P</i>	<i>b</i>	<i>o</i>

SELECTING THE PRINT FORMAT

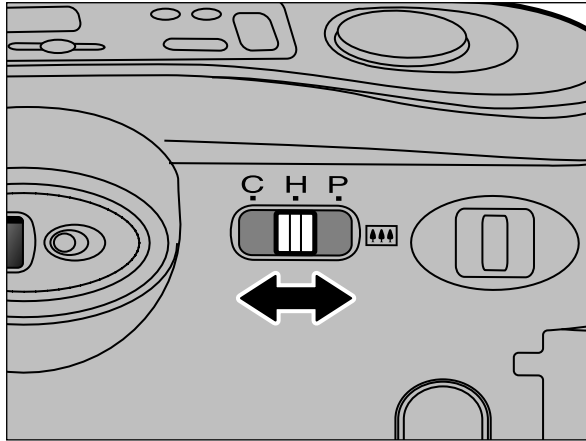

Fig. 12

With the Advanced Photo System

The style of print required can be selected from amongst C, H and P. Use the Format Selector to select the required print style.

* The print format can also be changed when making reprints, however the field of view remains the same.

Fig. 13

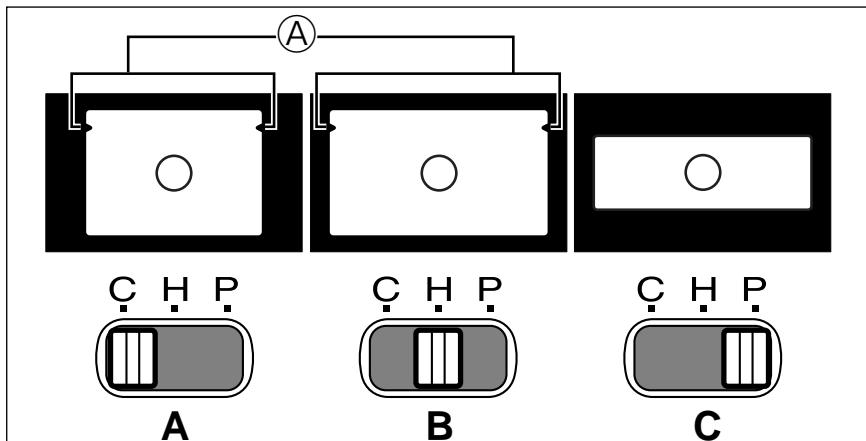

A C Print (2:3)

B H Print (9:16)

C P Print (1:3)

() represents the aspect ratio.

(Ⓐ) : Parallax correction mark

Fig. 14

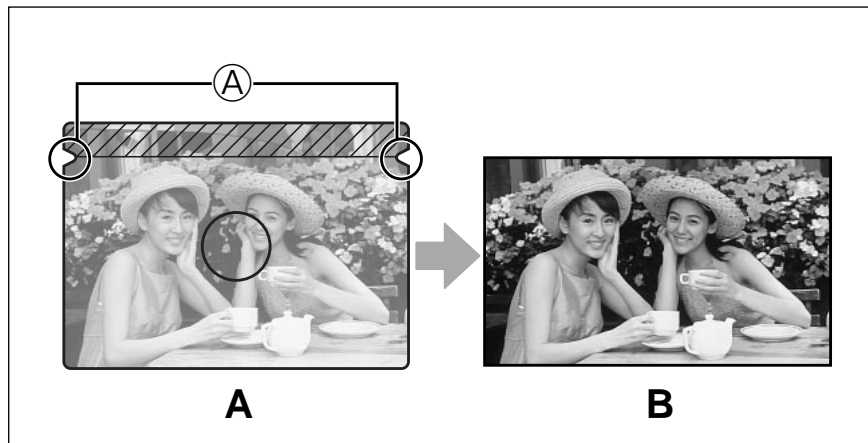

A: Viewfinder

B: Print finishing

● **With taking close-up picture**

When pictures are taken at distances closer than about 1.5m, the information within the  range shown above is not printed.

* When taking close ups, the area seen through the viewfinder and the area actually photographed will be different. (Because the viewfinder and the lens are in different locations.) The parallax correction mark is the criteria for the difference between the area seen through the viewfinder and the area actually photographed.

(Ⓐ : Parallax correction mark)

Fig. 15

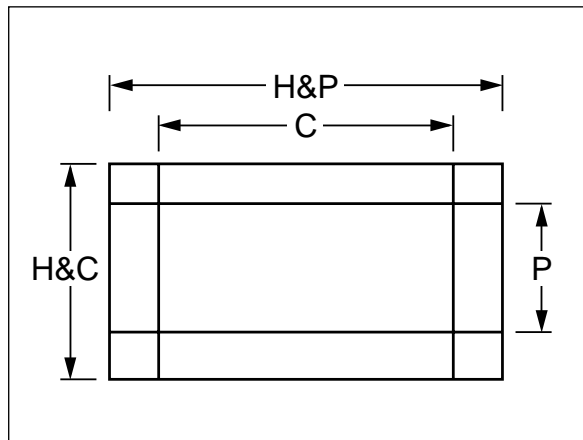

No matter what print format of the C/H/P was selected, the size of the photograph on the film may be the same(16.7 x 30.2mm). Depending on the print format selected during printing, the image (image of size in table) photographed within the area above may be printed.

C	H	P
about 16 x 23 mm	about 16 x 28 mm	about 10 x 28 mm

TAKING PICTURES

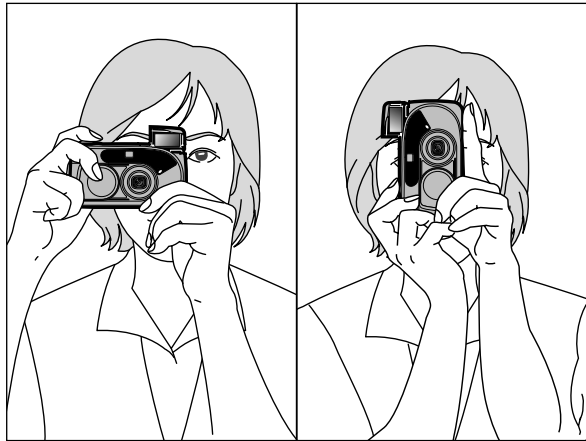

Fig. 16

Hold the camera firmly with both hands.

When holding vertically, keep the flash lamp upward.

* Be careful not to block the camera lens, flash and AE and AF Windows with your finger or strap.

The subject will not be focused correctly.

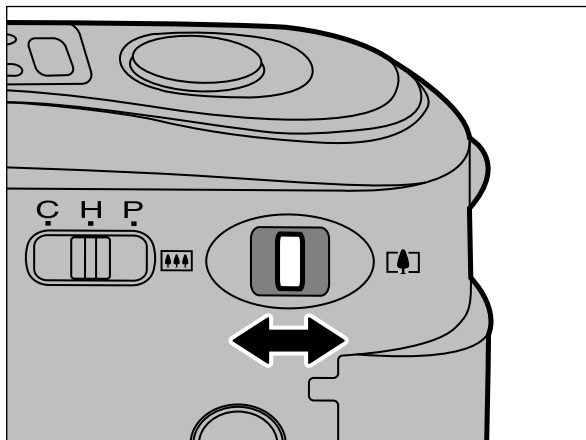

Fig. 17



If you want to increase the size of the subject, slide the zoom lever to the right  for a telephoto shot. If you want a wider field of view, slide the zoom lever to the left  for a wide-angle shot.



Fig. 18

Aim at the subject so that it fills the whole AF frame.
(Ⓐ : AF (Autofocus) frame)

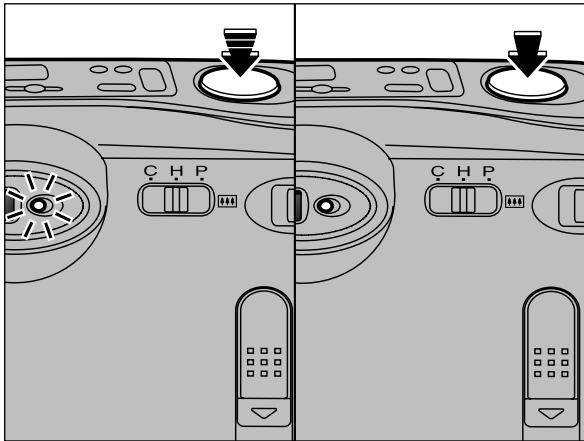

Fig. 19

When the shutter release button is pressed halfway and the AF lamp (green) turns on, focusing is complete. When the shutter trips, the flash fires and the film advances to the next frame.

- * While the shutter release button is pressed halfway, the film speed and type of film is indicated in the LCD.
- * When the camera is brought within about 1m of the subject, the AF lamp will blink to warn you that the subject is not focused. If the camera is brought about 30cm closer to the subject, the subject cannot be focused even if the AF lamp may light.
- * During the charging time of the flash, the shutter cannot be released.

- In dark places, photos should be taken within the following flash lamp ranges.

Effective Flash Lamp Ranges

Film speed	Wide angle (23mm)	Telephoto (69mm)
ISO 100	1.0 - 2.5	1.0 - 1.7
ISO 200	1.0 - 3.5	1.0 - 2.5
ISO 400	1.0 - 5.0	1.0 - 3.5

(Using color negative film; units; m)

- In the following cases, the camera may not be able to focus on the subject. Such subjects must be shot using the “Auto-Focus” lock or “Landscape Mode”. (refer to Fig. 20-22 and 32)
 - ① A bright light source such as the sun is near the subject or there is reflected light (from the windscreen of a vehicle, waves, etc.) near the subject.
 - ② A mirror or light-reflecting surfaces such as metals are near the center of the picture.
 - ③ When shooting black light-absorbing subjects such as hair.
 - ④ There are gaseous substances such as flame or smoke.
 - ⑤ Taking pictures through glass.

USING THE AUTO-FOCUS LOCK



Fig. 20

In the composition shown above, the AF frame is off the subject (in this case, the people). In this state, the Lens will not focus on the subject.



Fig. 21

Move the camera slightly so that the subject is inside the AF frame.

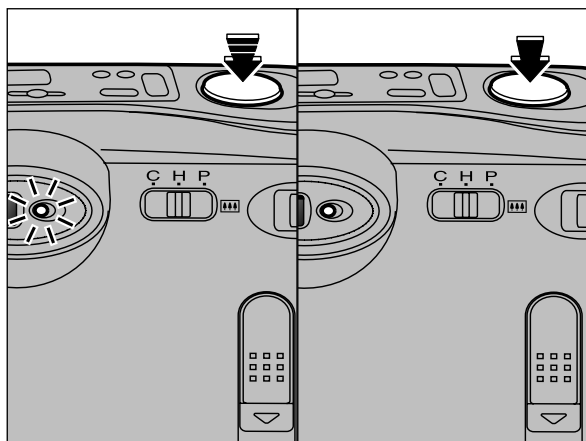

Fig. 22

Press the Shutter Release Button halfway down (AF lock) without moving the camera and confirm that the AF lamp (Green) lights.

While holding the Shutter Release Button halfway down to keep the Auto-Focus lock on, move the camera back to the original position to recompose your picture, then press the Shutter Release Button all the way down to take picture.

* The Auto-Focus lock operation can be repeated any number of times before the shutter trips.

UNLOADING THE FILM CARTRIDGE

Fig. 23

When the last frame has been exposed, and film is rewound. The Exposure Counter shows the number of frames remaining after subtracting the exposed frames from the specified number of frames. When rewinding of the film is finished, the “E” sign will appear on the Exposure Counter.

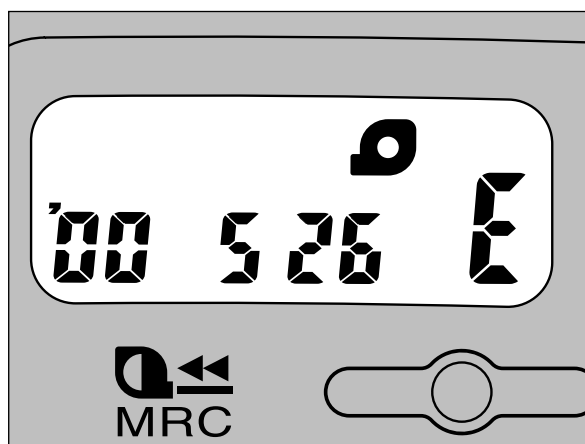

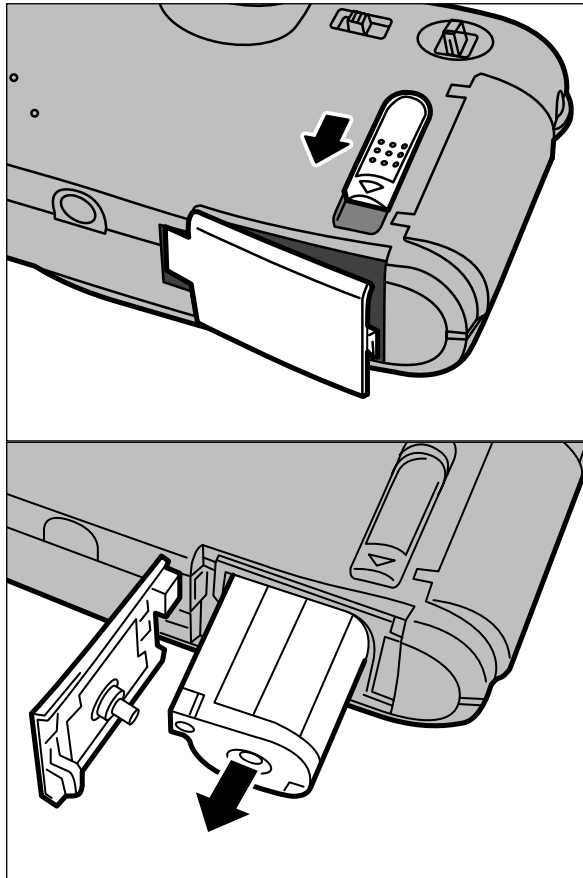

Fig. 24

After “E” sign appears in the Exposure Counter and the motor stops, move the Film Cartridge Compartment Cover Release Knob in the arrow direction, open the Film Cartridge Compartment Cover, and take out the cartridge.

- * Confirm the “E” sign in the Exposure Counter before opening the Film Cartridge Compartment Cover. Otherwise, camera trouble or accidental exposure of the film may occur.
- * Do not apply unnecessary force to the Film Cartridge Compartment Cover.

FILM CARTRIDGE MID-ROLL CHANGE FUNCTION

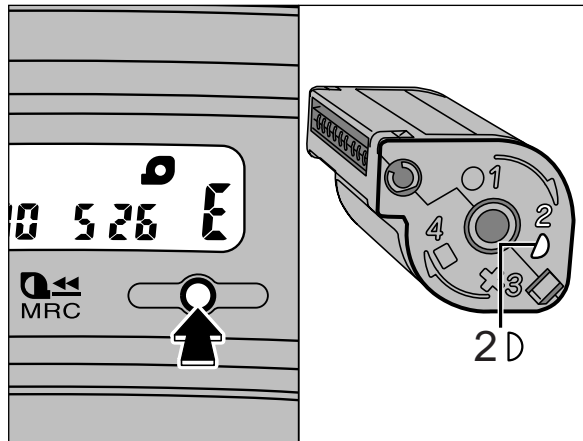

Fig. 25

When taking out the cartridge in mid-roll, turn on the power, by opening the Slide Cover, and then rewind the film by pressing the MRC (Mid-Roll Change) Button. When “E” is displayed on the Exposure Counter and the motor stops, take out the cartridge. Confirm that D 2 sign on the cartridge is white.

* If the MRC button is pressed when the power is off, the film may not be rewound. Turn on the power before rewinding the film.

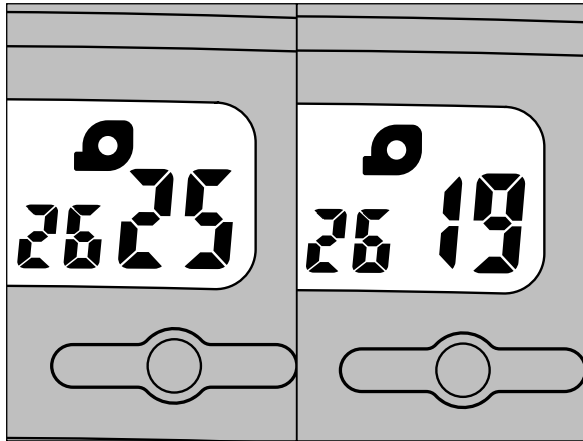

Fig. 26

Load a new film cartridge (with a white ○ cartridge status mark). The film will be advanced to the first frame, and the number of exposures specified on the film cartridge will appear on the LCD.

When the film cartridge unloaded in a mid-roll (with ◻ cartridge status mark) is loaded again, the film will be advanced automatically to the first unexposed frame allowing you to use the film continuously.

* Even if you forget how many frames you have exposed in the film cartridge changed in mid-roll, there is no problem. Load the film cartridge again. Your camera will automatically set the film to the first unexposed frame, and the LCD will tell you how many more frames you can take pictures.

- **Cautions Concerning the Mid-roll Change Function**

- * When a cartridge that has been removed in mid-roll (D is displayed) is reloaded into the camera, if “E” blinks in the Exposure Counter, reload the cartridge once more, avoiding the following locations.
 - Anywhere near a drier, fan, vacuum cleaner, etc., which has a rotating motor.
 - Near an active TV or personal computer display.
- * If a cartridge is removed in mid-roll D and then loaded into a camera which does not have the MRC function, the cartridge will be set to exposed X and can no longer be used.
- * A cartridge removed in mid-roll X from a camera which does not have the MRC function cannot be used even if loaded into this camera.
- * If a cartridge is removed in mid-roll D and sent to the processor, all frames on the entire roll will be developed. Expose all frames on the roll before sending the cartridge to the processor for development.
- * Mid-Roll change of cartridge is guaranteed only among our FOTONEX/ENDEAVOR series and nexia series of cameras with MRC functions. If a cartridge exposed with another make of camera with an MRC function is used, operation may not be normal.

SELECTING THE EXPOSURE MODE

Fig. 27

Display the desired Exposure Mode or Self-timer Mode by pressing the Mode Button.

- * Back Light Compensation Flash Mode, Flash Off Mode, Landscape Mode and Self-timer Mode are cancelled automatically when the power is turned.
- * The Landscape Mode and Self-timer Mode are canceled each time a picture is taken.

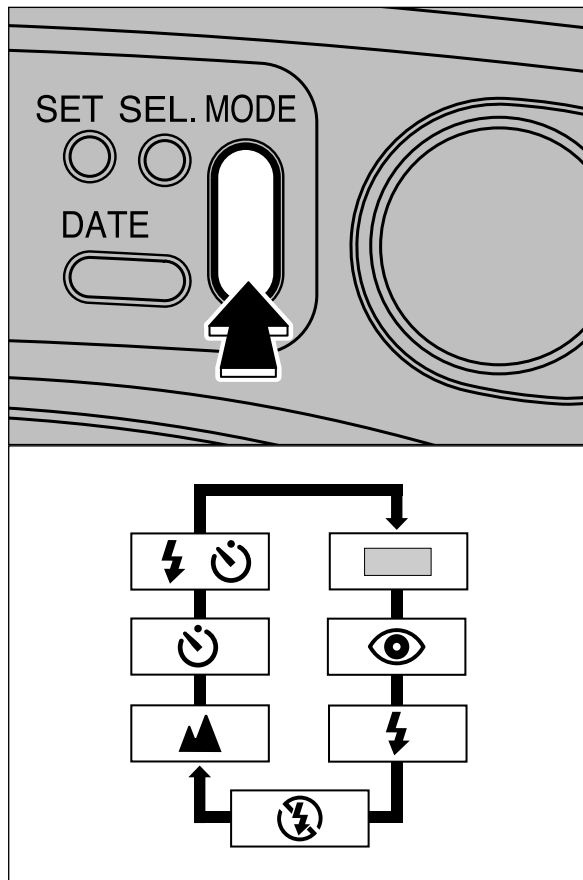



Fig. 28

( :no display) **Automatic Flash at low Brightness Mode**

Used when taking ordinary pictures

The flash lamp fires automatically when the brightness of the subject is lower than the predetermined level.

* When the Power Switch is turned on, the camera is automatically set to this mode.



Fig. 29

() **Red-eye Reduction Flash Mode**

Used when you want to take your object's pupils naturally in a dark place

The Red-eye Reduction Lamp turns on for about 1 second, then the camera takes a picture when the flash fires.

* Do not move the camera between pressing of the shutter release button and firing of the flash.
* The flash fires without regard to the brightness of the subject.

- **A word on red-eye**

When you photograph a person's face in dim light with flash, the eye will sometimes turn out red in the picture. This happens as the light from the flash enters the eyes and is reflected back into the camera lens. In the Red-eye Reduction Flash Mode, the subject's pupils are closed down before the flash fires.

In addition to using this mode, take the following actions:

- Ask the person being photographed to look directly at the camera.
- Take pictures by approaching as close as possible to the person.



Fig. 30

(⚡) Back Light Compensation Flash Mode

Used when taking against-the-light pictures of a person standing by a window or under the shade of a tree

Flash pictures taken even in a bright place.



Fig. 31

(🚫) Flash Off Mode

Used when taking pictures with the room illumination being utilized, or taking pictures of a remote subject to which the flash light does not reach, for example, in a theater or a stadium

The flash stops firing.

- * When taking pictures in a dark place, we recommend the use of a tripod to prevent the camera from shaking.



Fig. 32

(▲) Landscape Mode

Used when taking landscape pictures clearly or photographing remote (night) scenes through window glass

The lens is focused for the remote subjects. The flash does not fire under this mode.

- * This mode is automatically cancelled per shot.
- * When taking pictures in a dark place, we recommend the use of a tripod to prevent the camera from shaking.

SELECTING SELF-TIMER MODE

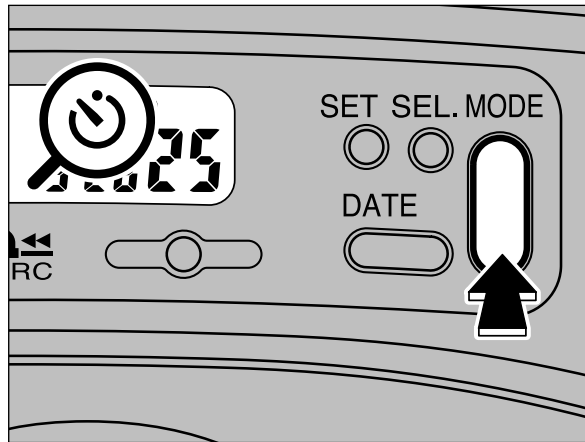



Fig. 33

Press the Mode Button to display the self-timer symbol “” on the LCD.

* In self-timer shooting, the “Automatic Flash at low Brightness Mode” or “Back Light Compensation Flash Mode” can be selected.

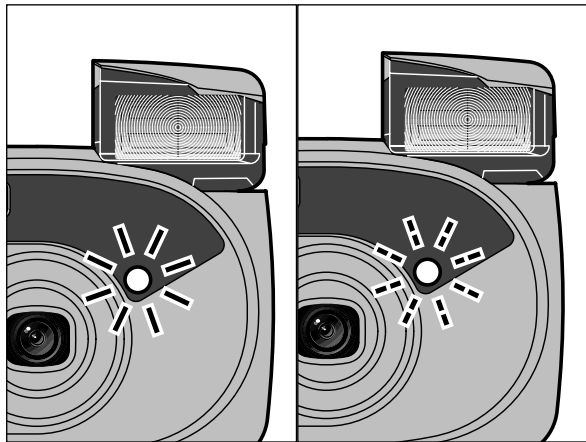

Fig. 34





Press the Shutter Release Button, and the Self-timer Lamp will turn on. Lamp lights steadily for 7 seconds, then blinks for remaining 3 seconds before flash the fires and the shutter is released. At the same time, the flash lamp fires in response to the brightness of the subject.

* Do not stand in front of the camera and press the shutter release button. It could cause poor focus or underexposure.

* The self timer mode is cancelled automatically when a photo is taken, or the power is turned off.

ERRORS, POSSIBLE CAUSES, AND REMEDIES

During operation

Error	Possible Causes	Remedies
<p>Exposure counter shows blinking “E  <ul style="list-style-type: none"> ● Open the film cartridge compartment cover and check the film cartridge status mark. Are you using a film cartridge with a white  (1) or  (2) cartridge status mark ? </p>	<ul style="list-style-type: none"> ● Unload the film cartridge and load an unused film cartridge or a film cartridge with unexposed frames remaining. 	
<p>A cartridge has been inserted, but the counter is not displayed on the LCD. The film will not wind.</p>	<ul style="list-style-type: none"> ● Check to ascertain that the batteries have been inserted after the cartridge. 	<ul style="list-style-type: none"> ● The shot will not be taken if the shutter was operated in this condition. Remove the cartridge without rewinding, and then reload it again.
<p>The shutter release won't trip.</p>	<ul style="list-style-type: none"> ① “ <ul style="list-style-type: none"> ① Replace the battery with a new one. ② Turn on the power by opening the slide cover and set the camera to the ready-to-shoot state. ③ Unload the film cartridge and load an unused film cartridge or a film cartridge with unexposed frames remaining. 	
<p>The film cartridge compartment cover cannot be opened.</p>	<ul style="list-style-type: none"> ● Are you attempting to unload the film carriage in the middle of a roll ? 	<ul style="list-style-type: none"> ● Rewind the film with the MRC Button. Unload the film cartridge after “E” appears in the exposure counter and the motor stops.
<p>The film is not rewound even if the MRC Button is pressed.</p>	<ul style="list-style-type: none"> ● Were pictures taken with the slide cover closed? 	<ul style="list-style-type: none"> ● Open the slide cover, then press the MRC Button again.

Printed pictures

Error	Possible Causes	Remedies
Picture is not sharp.	<ul style="list-style-type: none"> ① Was your finger on the AF windows when shooting? ② Did you focus on the subject correctly ? ③ Is the lens dirty ? ④ Was the camera shaking ? ⑤ Did you select ▲ mode when taking a close-up picture ? 	<ul style="list-style-type: none"> ① When shooting a picture, hold your camera correctly so that your finger is not on the AF windows. ② Make sure that the AF frame is on your subject or the use Auto-Focus lock technique. ③ Clean the lens. ④ Hold the camera firmly and press the shutter release button gently. When using slow shutter speeds, we recommend the use of a tripod. ⑤ Take pictures in other than ▲ mode.
Picture is dark.	<ul style="list-style-type: none"> ① Was the subject too far from the camera for flash photography in a dark place ? ② Was your finger over the flash ? 	<ul style="list-style-type: none"> ① Take pictures within the specified coverage distance of the flash. ② Be careful not to cover the flash with your finger.
Printed date (time) is incorrect.	<ul style="list-style-type: none"> ● Did you correct the date (time) after loading or replacing the battery ? 	<ul style="list-style-type: none"> ● Correct the date (time) after loading or replacing the battery.
The date is not printed on the front.	<ul style="list-style-type: none"> ① Wasn't "- - -" selected before taking pictures? ② Some photo finishers may not support printing on the front. 	<ul style="list-style-type: none"> ① Select a date mode other than "- - -" before taking pictures. ② Consult your nearest photo finisher.



SPECIFICATIONS

Film	IX240 cartridge film	Film Advance	Automatic motorized wind and rewind system, provisions for mid-roll rewinding and Cartridge Mid-Roll Replacement
Picture Size	16.7 x 30.2 mm	Flash	Pop-up Auto flash, 6 sec. recycle time. Automatic flash at low brightness mode/Red-eye Reduction flash mode/Back Light Compensation mode/Flash off mode
Print Format	C/H/P switchable	Self-timer	Electronically controlled, 10 seconds delay, self-timer on lamp
Lens	Fujinon Lens, 5 components, 5 elements, f=23 – 69 mm / 1:6.7 – 1:12.5	Liquid Crystal Display	Exposure Mode Sign, Self-timer Mode Sign, Battery Capacity Sign, Film Cartridge Mark, Date, Exposure Counter, Type of Film Cartridge, Film Sensitivity
Viewfinder	Real image zoom finder, 0.33 – 0.87 x magnification, with AF frame (C, H, and P formats switchable), parallax correction mark, AF lamp	Date Recording	Magnetic recording system. Recordable on each frame. Date, print type, and PQI (Picture Quality Improvement) information
Focusing	Active infrared auto focus 1m – ∞ with AF lock, landscape mode (long distance lens position setting, flash off setting), AF lamp (turns on when focusing completes)	Power Supply	One lithium battery, CR 123A /DL 123A or equivalent
Shutter	Programmed electronic shutter (1/8 – 1/300 sec.)	Others	Built-in lens cover; with tripod socket
Exposure Control	Automatic, interlocking range (ISO 200) W: EV11 – 14 T: EV13 (*11) – 14 (* is when the flash is disabled.)	Dimensions & Weight	113.5 x 62.0 x 42.5 mm 175 g (without battery)
Film Speed Setting	Automatic (Date Disc System), ISO 100, 200, 400		
Film Loading	Single touch drop-in loading system, Film safety lock system with optical erroneous loading prevention system		

* Specifications are subject to change without notice.



CAMERA CARE AND CAUTIONS

1. Your camera is a precision instrument which requires careful handling. Do not expose it to shock, liquid, or drop it on the floor.
 - 1) If you use the camera at the seaside or in light rain, be careful not to get it wet. Also be careful not to put the camera in places where it will be easily exposed to sand.
 - 2) Dropping the camera on the floor or striking it against hard objects sometimes causes trouble even though it may be in the camera case. Also do not put the camera in places where it is exposed to vibrations (such as the trunk of a car).
2. If you are not using your camera for a long time, keep it where it will be safe from heat, moisture, dust, and harmful gases (such as naphthalene which is used in drawers).
3. Since this camera is computer-controlled, it almost never operates erroneously. If erroneous operation should occur, remove and then reload the battery.
4. This advanced photo system magnetically records the information on the film. Therefore, do not expose film cartridges or a film cartridge loaded camera to strong magnetic fields.
5. Do not put the camera in a closed car for a long time.
6. It is recommended that undeveloped film and cameras containing film are carried as hand luggage when using aircraft. If included in checked-in baggage, X-ray inspections may cause overprinting or other effects.
7. Remove soil and dust from the lens, the AF window and the finder with an air blower and by wiping lightly with a piece of soft cloth. If that is not enough, wipe off gently with Lens Cleaning Paper, moistened slightly with Lens Cleaning Liquid. Do not use organic solvents such as alcohol and benzene.
8. The operating temperature range of the camera is from -10°C to $+40^{\circ}\text{C}$.



26-30, Nishiazabu 2-chome, Minato-ku, Tokyo 106-8620, Japan.

<FUJIFILM ABROAD>

In North America

FUJI PHOTO FILM U.S.A., INC.

555 Taxter Road, Elmsford, N.Y. 10523, U.S.A.

FUJI PHOTO FILM CANADA INC.

275 Britannia Road East, Mississauga, Ontario, L4Z 2E7, Canada

FUJI PHOTO FILM HAWAII, INC.

1650 Kalakaua Avenue, Honolulu, Hawaii 96826, U.S.A.

In Europe

FUJI PHOTO FILM (EUROPE) G.m.b.H.

Heesenstrasse 31, 40549 Dusseldorf, Germany

FUJI PHOTO FILM (U.K.) LTD.

Fuji Film House, 125 Finchley Road, Swiss Cottage, London NW3 6JH, England

FUJI FILM ESPAÑA, S.A.

Aragon, 180, 08011-Barcelona, Spain

In South America

FUJI PHOTO FILM DO BRAZIL LTDA.

Avenida Vereador Jose Diniz No. 3.400, Campo Belo- CEP 04.604

Cx. Postal 9.959., Sao Paulo-SP, Brazil

In Asia

FUJI PHOTO FILM CO., LTD., HONG KONG OFFICE

Room 916, Sun Plaza, 28 Canton Road, Tsim Sha Tsui, Kowloon, Hong Kong

FUJI PHOTO FILM (SINGAPORE) PTE. LTD.

10 New Industrial Road, Singapore 536201

FUJI PHOTO FILM (THAILAND) LTD.

S.P. Building, 8th Floor, 388 Phaholyothin Road, Bangkok 10400, Thailand

FUJI PHOTO FILM (MALAYSIA) SDN. BHD.

Letter Box 3, 3rd Floor Office Block 1, Crystal Plaza Lot 4, Jalan 51A/223, 46100 Petaling Jaya Selangor Darul Ehsan Malaysia

FUJI PHOTO FILM CO., LTD., TAIPEI OFFICE

Rm. 601, Hung Chong Bldg., No.38, Sec. 6, Min Chuan E. Road, Taipei 11412, Taiwan, Republic of China

FUJI PHOTO FILM CO., LTD., SEOUL OFFICE

Samduck Bldg. 6F., 144-1, Samsung-Dong, Kang Nam-ku, Seoul 135-090, Korea

FUJI PHOTO FILM CO., LTD., BEIJING REPRESENTATIVE OFFICE

Beijing Fortune Bldg. No. 817, 5, Dong Sanhuan Bei-lu, Chaoyang District, Beijing, China 100004

FUJI PHOTO FILM CO., LTD., HO CHI MINH OFFICE

29-31 Ton That Thiep St., Q.I Ho Chi Minh City, Vietnam

FUJI PHOTO FILM CO., LTD., NEW DELHI OFFICE

Le Meridian Commercial Tower 8F Janpath, New Delhi 110001, India

In Oceania

FUJI PHOTO FILM CO., LTD., SYDNEY REPRESENTATIVE OFFICE

c/o Hanimex Pty. Limited, Old Pittwater Road, Brookvale, N.S.W. 2100, Australia

In Middle East

FUJI PHOTO FILM CO., LTD., DUBAI OFFICE

No. 4G-17, L.O.B. No. 4, P.O. BOX 17212, Jebel Ali, Dubai, U.A.E.